

---

# OPERATING INSTRUCTIONS

MIBO-PEKT-116001

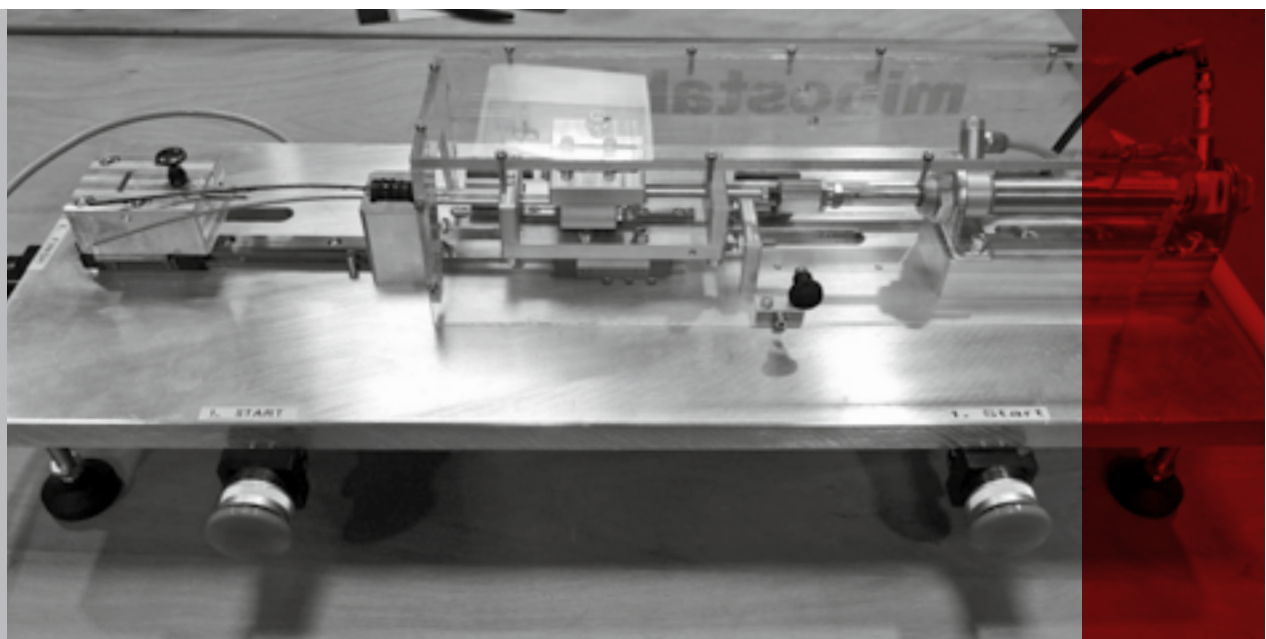

**MIBOstahl**<sup>®</sup>  
made in germany

---

---

# TABLE OF CONTENTS



03	DECLARATION OF CONFORMITY
04	SAFETY INSTRUCTIONS
04	GENERAL INSTRUCTIONS
05	GENERAL SAFETY INSTRUCTIONS
05	PROHIBITED OPERATING MODES
06	DISPOSAL
06	TRANSPORT
06	USE AND INTENDED PURPOSE
07	TECHNICAL DATA
07	CIRCUIT DIAGRAM
08	TECHNICAL DRAWING
09	LIST OF SPARE PARTS
10	HAZARD PREVENTION
10	COMMISSIONING
10	MAINTENANCE
11	POSSIBLE MALFUNCTIONS

# DECLARATION OF CONFORMITY

We hereby declare that the design of the assembly machine shown on the front page satisfies all relevant, fundamental health and safety requirements.



## EC DIRECTIVES

EC Machinery Directive (2006/42/EG)

## APPLIED HARMONISED STANDARDS

Standard	Version	Description
DIN EN ISO 12100:2011	03.2011	Safety of machinery Basic terms; general principles for design
DIN EN 349:1993+A1	09.2008	Safety of machinery – Minimum gaps to avoid crushing of parts of the human body
DIN EN 14120	05.2016	Safety of machinery – Guards – General requirements for the design and construction of fixed and movable guards
DIN EN ISO 13849-1	06.2016	Safety of machinery – Safety-related parts of control systems – Part 1: General principles of design
DIN 4844-1	06.2012	Graphical symbols – Safety colours and safety signs – Part 1: Observation distances and colorimetric and photometric requirements
DIN 4844-2:2012-06	12.2012	Graphical symbols – Safety colours and safety signs – Part 2: Registered safety signs
DIN EN 61310-3	09.2008	Safety of machinery – Indication, marking and actuation – Part 3: Requirements for the location and operation of actuators (IEC 61310-3:2007)
DIN EN 1005-2:2009-05	05.2009	Safety of machinery – Human physical performance – Part 2: Manual handling of machinery and component parts of machinery
DIN EN ISO 4414	04.2011	Pneumatic fluid power – General rules and safety requirements for systems and their components
DIN EN 574	12.2008	Safety of machinery – Two-hand control devices – Functional aspects – Principles for design
DIN EN 1037:2008-11	08.2011	Safety of machinery – Prevention of unexpected start-up

---

# SAFETY INSTRUCTIONS



Wear suitable work clothing!



Attention! Risk of crushing!



Always depressurise before conducting maintenance and servicing!

---

## GENERAL INSTRUCTIONS

The device is an assembly unit to introduce cables into a sleeve according to Scania specification 1512156.

The assembly unit is built according to the state of the art and the recognised rules of technical safety, and has completed a functional test.

Operation of the unit may nevertheless pose risks to the health of the operator and third persons, or impair the assembly unit and other material assets.

All persons involved in the installation, commissioning, operation and maintenance of the assembly unit must read the following instructions carefully.

It is a question of your safety!

---

# GENERAL SAFETY INSTRUCTIONS

- Staff must be instructed in occupational health and safety
- Staff must be trained in handling the assembly unit
- The assembly unit must always be depressurised when not in use
- Depressurisation must be checked before any maintenance and repairs The device is considered depressurised 2 minutes after disconnection from the compressed air system
- It is prohibited to operate the assembly unit without hose breakage protection
- Only means of transport and tools that are of a sufficient size for the anticipated load when performing installation, assembly and disassembly may be used
- Safety shoes must be worn when transporting the assembly unit
- Use of the assembly unit for assembly processes is only permitted if the protective hood is locked shut
- It is prohibited to bypass or switch off two-hand operation
- The assembly unit must only be used for the assembly of cables and sleeves according to Scania diagram 1512156
- The workplace must be sufficiently illuminated as defined in the German Workplace Ordinance (Arbeitsstättenverordnung)
- Instructions provided in the signage must be observed

---

## PROHIBITED OPERATING MODES

- It is prohibited for there to be any parts in the operating area that do not comply with Scania diagram 1512156

---

# DISPOSAL

- All materials used are harmless as defined by REACH
  - Metals can be disposed of as scrap
  - Plastics are disposed of as residual waste
- 

# TRANSPORT

- The cover on the pneumatic parts must be attached to the base of the assembly unit during transport
  - The assembly unit must be disconnected from the compressed air system and pressurisation guaranteed before transport
  - Moving parts must be secured in place during transport
  - The assembly unit must be checked for damage after each transport
- 

# USE AND INTENDED PURPOSE

- The assembly unit must only be used for the installation of cables and sleeves according to Scania diagram 1512156
  - We are unable to guarantee safe functions in the event that other cable diameters than those delivered are used
-

# TECHNICAL DATA

- Weight: 18 kg
- Dimensions L/W/H: 700x280x240
- Compressed air ISO 8573-1, max. 8 bar

# CIRCUIT DIAGRAM

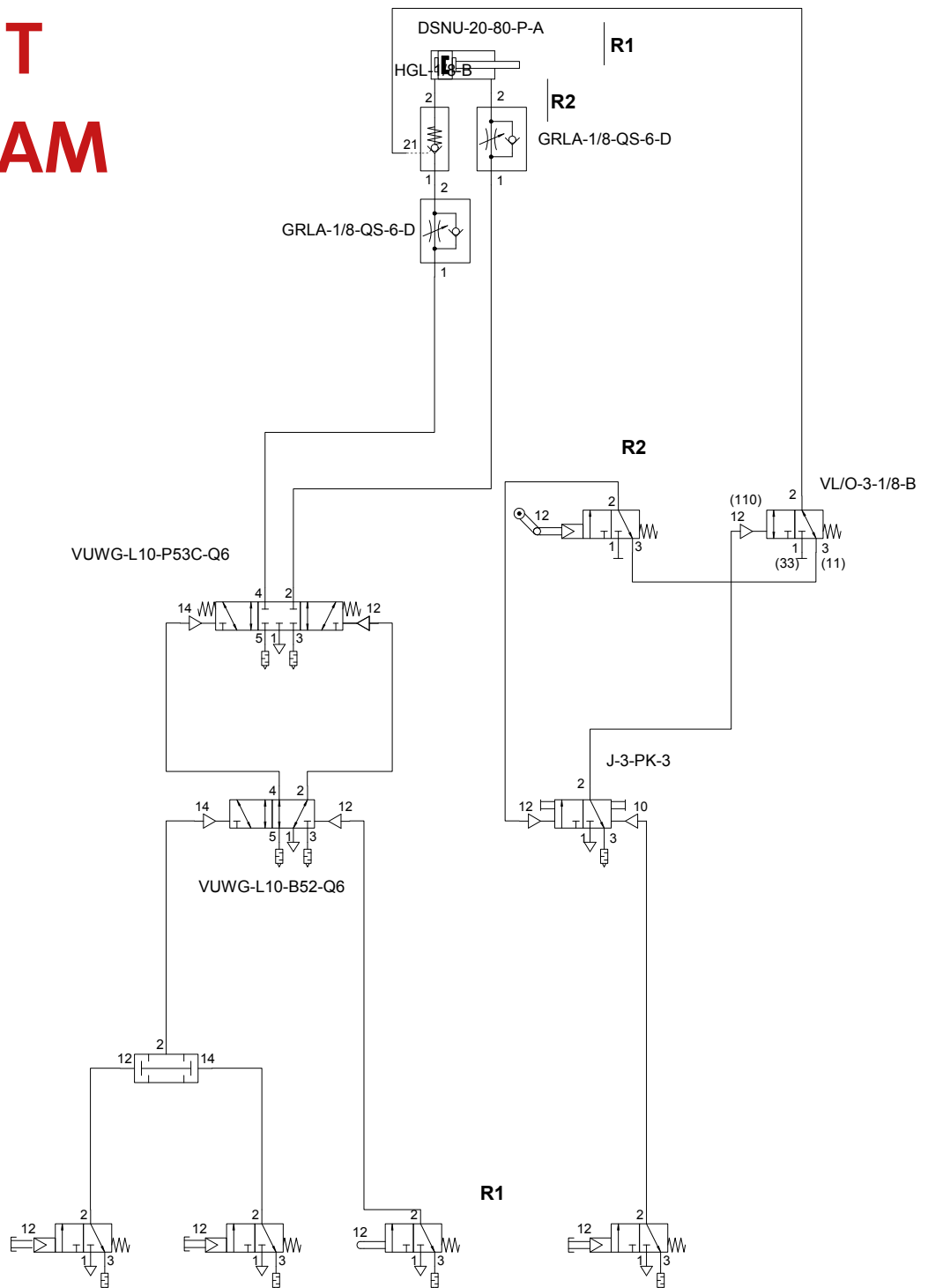

# MIBO-PEKT-116001

**MIBOSTAHL**<sup>®</sup>  
made in germany

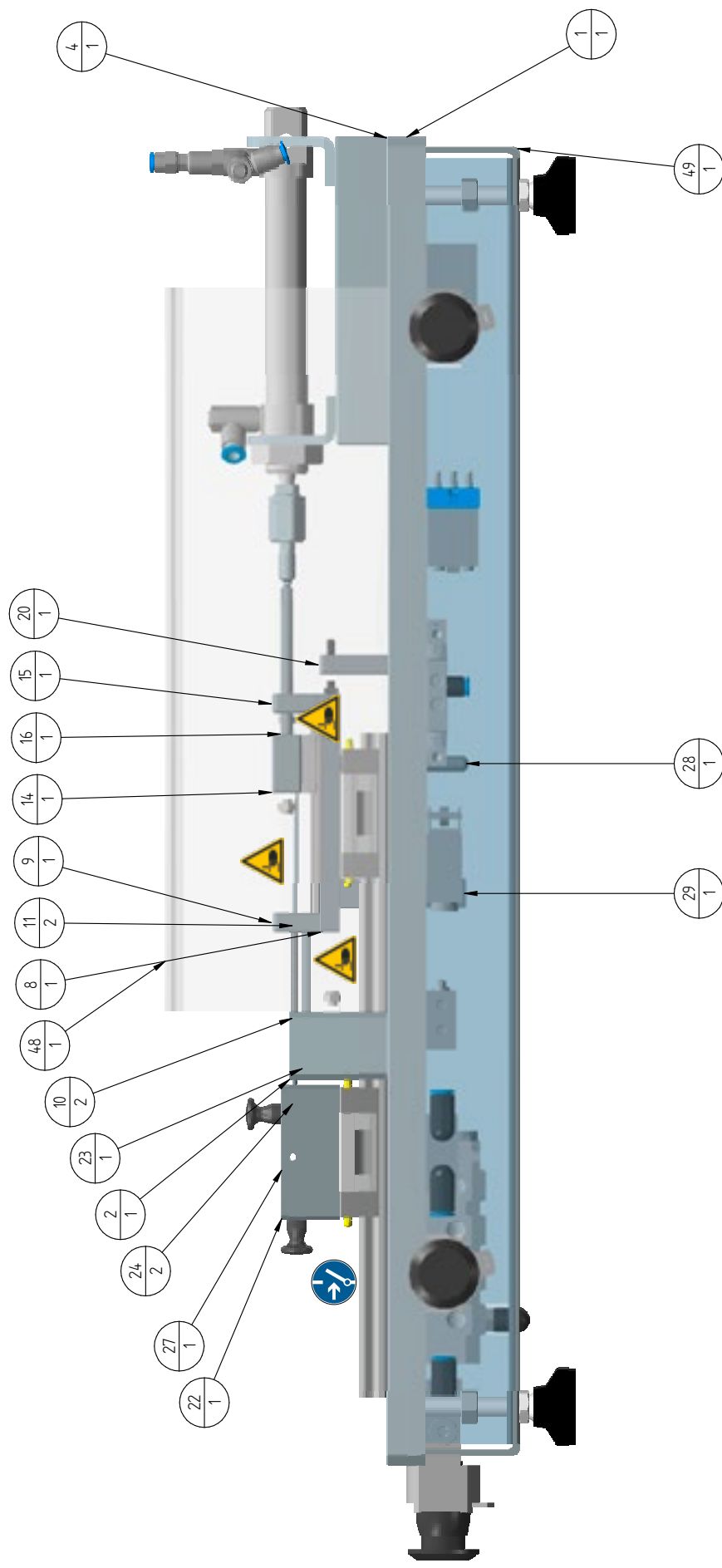



# LIST OF SPARE PARTS

MIBO-PEKT-116001

Position	File name (without file extension)	Number
1	Base plate	1
2	Assembly of the sleeve receiver Installation	1
4	Distance piece	1
8	Guide sleeve holder	1
9	Sleeve receiver	1
10	Guide sleeve – closed	2
11	Core	2
14	Core holder	1
15	Stop plate	1
16	Pressure-tension bolt	1
20	Stop plate magnet	1
22	Counter-bearing	1
23	Counter-pressure bolt	1
24	Alignment pins	2
27	Sleeve receiver	1
28	Sensing pin	1
29	Sensing arm	1
48	Safety cover	1
49	Hose cover	1

---

# HAZARD PREVENTION

- Protective hood above the compressed air cylinder stroke
  - Two-hand solution according to type I
  - Base plate to protect the compressed air hoses during transport
  - Hose breakage protection
- 

# COMMISSIONING

- There must be no foreign parts in the operating area during connection to the compressed air system
  - The unit must be installed on a level, anti-slip floor
  - All covers, screw connections and safety systems must be checked for good working order before commissioning
  - The compressed air used must satisfy the requirements defined in ISO 8573-1, Category 7:4:4
- 

# MAINTENANCE

- Depressurisation must be checked before any maintenance and repairs The device is considered depressurised 2 minutes after disconnection from the compressed air system
-



The points marked here must be lubricated once yearly with industry-standard grease for sliding guides.

The assembly unit is otherwise maintenance-free.

## POSSIBLE MALFUNCTIONS

- There were no malfunctions during testing

---

**MIBostahl**<sup>®</sup>  
tools, trading and service GmbH

Hochofenstrasse 6  
58135 Hagen | Germany  
Fon +49 (0) 2331 377578-0  
Fax +49 (0) 2331 377578-20  
info@mibostahl.de  
mibostahl.com